

Revision Notes.

R1 - PN CORRECTED FROM 4469 TO 4569

APA: D.LAM Drawn-A:FEDERIGHI Checked-R:BATES Approved-B:JOHN Date: 03/12/2013

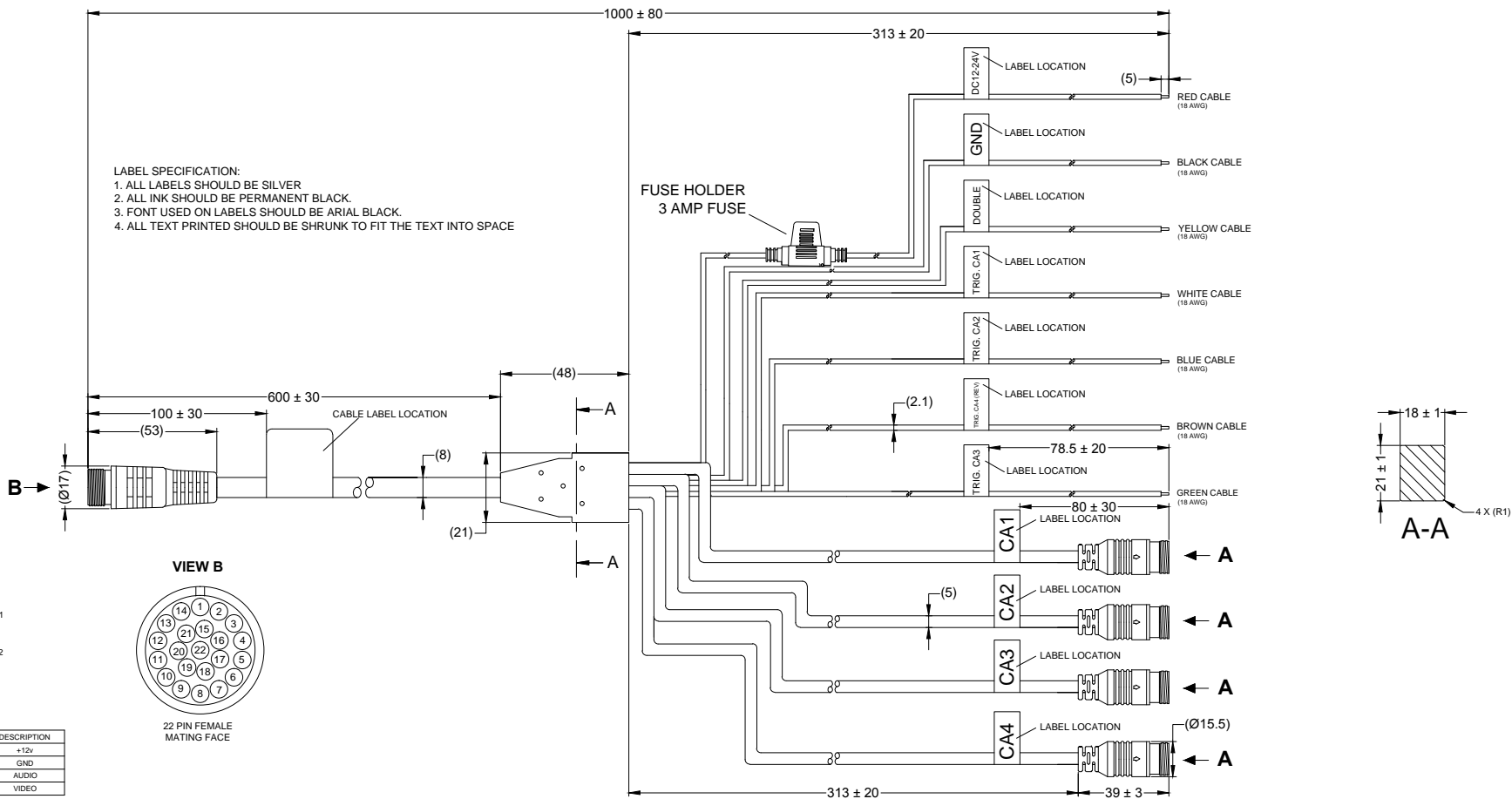

LABEL SPECIFICATION:
 1. ALL LABELS SHOULD BE SILVER
 2. ALL INK SHOULD BE PERMANENT BLACK.
 3. FONT USED ON LABELS SHOULD BE ARIAL BLACK.
 4. ALL TEXT PRINTED SHOULD BE SHRUNK TO FIT THE TEXT INTO SPACE

VIEW A



4 PIN MALE MATING FACE

PIN #	WIRE COLOUR	DESCRIPTION
1	RED	+12V
2	BLACK/SHIELD	GND
3	WHITE	AUDIO
4	YELLOW	VIDEO

VIEW B



22 PIN FEMALE MATING FACE

VIEW B WIRE COLOUR	RED	WHITE/BLUE	BLUE	BROWN	PURPLE	SHIELD	YELLOW	GREY	LIGHT RED	WHITE	LIGHT GREEN	GREEN	WHITE/RED	WHITE/PURPLE	ORANGE	LIGHT BLUE	BLACK	WHITE/ORANGE	WHITE/LIGHT GREEN	WHITE/BLACK	WHITE/LIGHT BROWN	SHIELD
VIEW B PIN NUMBER	1	2	3	4	5	6	7	8	9	10	11	12	13	14	15	16	17	18	19	20	21	22
CA1	/	/	/	/	/	2	4	3	1	/	/	/	/	/	/	/	/	/	/	/	/	/
CA2	/	/	/	/	/	2	/	/	/	4	3	/	1	/	/	/	/	/	/	/	/	/
CA3	/	/	/	/	/	2	/	/	/	/	/	/	/	1	/	4	3	/	/	/	/	/
CA4	/	/	/	/	/	2	/	/	/	/	/	/	/	/	4	3	1	/	/	/	/	/
COLOUR	RED	GREEN	BLUE	BROWN	WHITE	BLACK	YELLOW	WHITE	RED	YELLOW	WHITE	BLACK	RED	YELLOW	WHITE	RED	YELLOW	AUDIO	YELLOW	DOUBLE	/	/
DESCRIPTION	DC12-24V	TR-CA3	TR-CA2	TR-CA4	TR-CA1	GND	CA1 VID	CA1 AUD	CA1 12V	CA2 VID	CA2 AUD	GND	CA2 12V	CA3 12V	CA4 VID	CA4 AUD	CA4 12V	CA3 VID	CA3 AUD	DOUBLE	/	/

NOTES:

- FOR CABLE LABEL SPECIFICATION REFER TO LATEST REVISION OF DRAWING: BE-001500-XX-11.
- CABLE TO BE HELD NEATLY TOGETHER BY TWIST TIE.
- CAMERA CONNECTOR MUST BE BLACK.
- ALL STRIPPED ENDS SHOULD BE TINNED.
- CONNECTOR GUIDES MUST LINE UP WITH ARROWS
- FOR MANUFACTURE CONTROL REFER TO ASSEMBLY PLANT DRAWING NO. SV412-18 REV. 1.0
- MAXIMUM POSSIBLE RESISTANCE PERMITTED FOR CABLE IS 1.2Ω.

PROPRIETARY NOTICE

THIS DESIGN AND TECHNICAL INFORMATION APPEARING ON THIS DRAWING IS THE PROPERTY OF BRIGADE ELECTRONICS, AND IS DISCLOSED IN CONFIDENCE. IT IS NOT TO BE COPIED, REPRODUCED, REVEALED TO OR EXPROPRIATED BY OTHERS, EITHER IN WHOLE OR IN PART WITHOUT THE EXPRESS WRITTEN CONSENT OF BRIGADE ELECTRONICS.



Assembly Pl Approval DONGQING LAM (5/11/13)	Approved by S.MATTHEWS	Checked by M.BUTLER	Drawn by A.FEDERIGHI
Angle of Projection 	Units mm	Scale N/A	Released 06/11/13
	Status RELEASED	Assembly Ref VBV-7104FM-CA	
	Part No 4569	BE-002664-01-13	